

SFLH
Safety Fast Lite Hanger - Solid Joists

The SFLH is an innovative single piece hanger designed to support timber joists from masonry walls, without the need for masonry above the course of blockwork supporting the hanger.

CE

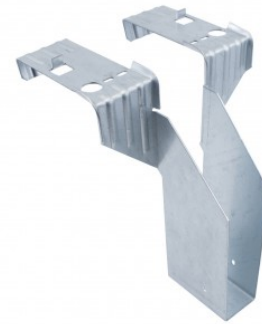

Features

Benefits

The SFLH has been designed to assist in meeting the air leakage requirements as part of the Code for Sustainable Homes. Since the joist is supported by a hanger and does not penetrate the inner leaf of blockwork, the potential for air leakage is reduced and avoids the time consuming and costly mortaring and sealing with mastic around built in joist ends. This hanger allows construction work to continue safely just 3 days after the supporting blockwork has been laid - as opposed to 28 days in the case of traditional masonry hangers.

- Avoids joist penetrating block work, minimising air leakage.
- Achieves published performance values with no masonry above the supporting course of block work.
- Enables the construction of the floor deck prior to the next lift of masonry.
- Reduces health & safety risks associated with the use of traditional masonry hangers with no masonry courses above them.
- Eliminates the need for propping to support the floor joists.
- Web stiffeners are not required with joists to achieve published performance values.
- Use FMS strap range with every hanger spaced up to 600mm centres to provide lateral restraint of the floor joist in accordance with EN845-1.
- If using HES restraint straps, place at 2 metre centres.
- CE Approved: meets the requirements of EN845-1 and tested in accordance with EN 846-8.

Material

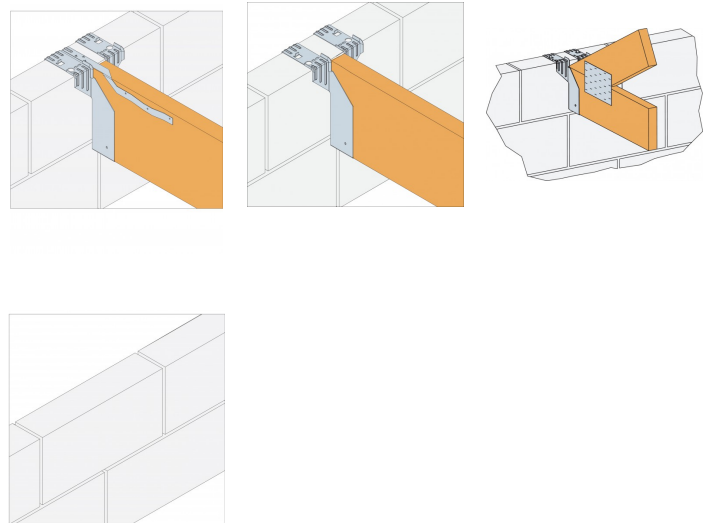

SFLH
Safety Fast Lite Hanger - Solid Joists

Technical Data

Technical data sheet



SFLH Safety Fast Lite Hanger - Solid Joists

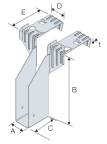

Production Dimensions

References	Joist Size [mm]		Product Dimensions [mm]							Joist holes	
	Width	Height	A	B	C	D	E	F	t	Hanger holes	FMS Strap
										Ø6x4	Ø4.2
SFLH100/38	35	100	38	100	75	49.5	103	81	1.5	2	3
SFLH125/38	35	125	38	125	75	49.5	103	81	1.5	2	3
SFLH150/38	35	150	38	140	75	49.5	103	81	1.5	2	3
SFLH175/38	35	175	38	165	75	49.5	103	81	1.5	2	3
SFLH200/38	35	200	38	190	75	49.5	103	81	1.5	2	3
SFLH225/38	35	225	38	215	75	49.5	103	81	1.5	2	3
SFLH250/38	35	250	38	240	75	49.5	103	81	1.5	2	3
SFLH300/38	35	300	38	290	75	49.5	103	81	1.5	2	3
SFLH100/44	44	100	44	100	75	49.5	103	81	1.5	2	3
SFLH125/44	44	125	44	125	75	49.5	103	81	1.5	2	3
SFLH150/44	44	150	44	140	75	49.5	103	81	1.5	2	3
SFLH175/44	44	175	44	165	75	49.5	103	81	1.5	2	3
SFLH200/44	44	200	44	190	75	49.5	103	81	1.5	2	3
SFLH225/44	44	225	44	215	75	49.5	103	81	1.5	2	3
SFLH250/44	44	250	44	240	75	49.5	103	81	1.5	2	3
SFLH300/44	44	300	44	290	75	49.5	103	81	1.5	2	3
SFLH100/47	45	100	47	100	75	49.5	103	81	1.5	2	3
SFLH125/47	45	125	47	125	75	49.5	103	81	1.5	2	3
SFLH150/47	45	150	47	140	75	49.5	103	81	1.5	2	3
SFLH175/47	45	175	47	165	75	49.5	103	81	1.5	2	3
SFLH200/47	45	200	47	190	75	49.5	103	81	1.5	2	3
SFLH225/47	45	225	47	215	75	49.5	103	81	1.5	2	3
SFLH250/47	45	250	47	240	75	49.5	103	81	1.5	2	3
SFLH300/47	45	300	47	290	75	49.5	103	81	1.5	2	3
SFLH100/50	50	100	50	100	75	49.5	103	81	1.5	2	3
SFLH125/50	50	125	50	125	75	49.5	103	81	1.5	2	3
SFLH150/50	50	150	50	140	75	49.5	103	81	1.5	2	3
SFLH175/50	50	175	50	165	75	49.5	103	81	1.5	2	3
SFLH200/50	50	200	50	190	75	49.5	103	81	1.5	2	3
SFLH225/50	50	225	50	215	75	49.5	103	81	1.5	2	3
SFLH250/50	50	250	50	240	75	49.5	103	81	1.5	2	3
SFLH300/50	50	300	50	290	75	49.5	103	81	1.5	2	3
SFLH100/63	63	100	63	100	75	49.5	103	81	1.5	2	3
SFLH125/63	63	125	63	125	75	49.5	103	81	1.5	2	3
SFLH150/63	63	150	63	140	75	49.5	103	81	1.5	2	3
SFLH175/63	63	175	63	165	75	49.5	103	81	1.5	2	3
SFLH200/63	63	200	63	190	75	49.5	103	81	1.5	2	3
SFLH225/63	63	225	63	215	75	49.5	103	81	1.5	2	3
SFLH250/63	63	250	63	240	75	49.5	103	81	1.5	2	3
SFLH300/63	63	300	63	290	75	49.5	103	81	1.5	2	3
SFLH100/75	75	100	75	100	75	49.5	103	81	1.5	2	3
SFLH125/75	75	125	75	125	75	49.5	103	81	1.5	2	3
SFLH150/75	75	150	75	140	75	49.5	103	81	1.5	2	3
SFLH175/75	75	175	75	165	75	49.5	103	81	1.5	2	3

Technical data sheet



SFLH Safety Fast Lite Hanger - Solid Joists

References	Joist Size [mm]		Product Dimensions [mm]							Joist holes	
	Width	Height	A	B	C	D	E	F	t	Hanger holes	FMS Strap
										Ø6x4	Ø4.2
SFLH200/75	75	200	75	190	75	49.5	103	81	1.5	2	3
SFLH225/75	75	225	75	215	75	49.5	103	81	1.5	2	3
SFLH250/75	75	250	75	240	75	49.5	103	81	1.5	2	3
SFLH300/75	75	300	75	290	75	49.5	103	81	1.5	2	3
SFLH100/91	2x45 or 91	100	91	100	75	49.5	103	81	1.5	2	3
SFLH125/91	2x45 or 91	125	91	125	75	49.5	103	81	1.5	2	3
SFLH150/91	2x45 or 91	150	91	140	75	49.5	103	81	1.5	2	3
SFLH175/91	2x45 or 91	175	91	165	75	49.5	103	81	1.5	2	3
SFLH200/91	2x45 or 91	200	91	190	75	49.5	103	81	1.5	2	3
SFLH225/91	2x45 or 91	225	91	215	75	49.5	103	81	1.5	2	3
SFLH250/91	2x45 or 91	250	91	240	75	49.5	103	81	1.5	2	3
SFLH300/91	2x45 or 91	300	91	290	75	49.5	103	81	1.5	2	3
SFLH100/96	2x47	100	96	100	75	49.5	103	81	1.5	2	3
SFLH125/96	2x47	125	96	125	75	49.5	103	81	1.5	2	3
SFLH150/96	2x47	150	96	140	75	49.5	103	81	1.5	2	3
SFLH175/96	2x47	175	96	165	75	49.5	103	81	1.5	2	3
SFLH200/96	2x47	200	96	190	75	49.5	103	81	1.5	2	3
SFLH225/96	2x47	225	96	215	75	49.5	103	81	1.5	2	3
SFLH250/96	2x47	250	96	240	75	49.5	103	81	1.5	2	3
SFLH300/96	2x47	300	96	290	75	49.5	103	81	1.5	2	3
SFLH100/99	2x50 or 97 or 100	100	100	100	75	49.5	103	81	1.5	2	3
SFLH125/99	2x50 or 97 or 100	125	100	125	75	49.5	103	81	1.5	2	3
SFLH150/99	2x50 or 97 or 100	150	100	140	75	49.5	103	81	1.5	2	3
SFLH175/99	2x50 or 97 or 100	175	100	165	75	49.5	103	81	1.5	2	3
SFLH200/99	2x50 or 97 or 100	200	100	190	75	49.5	103	81	1.5	2	3
SFLH225/99	2x50 or 97 or 100	225	100	215	75	49.5	103	81	1.5	2	3

Product characteristic capacities

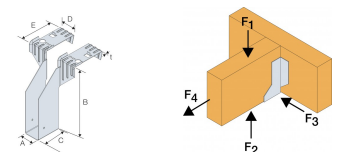

References	Number of Fasteners				Characteristic Capacities [kN]			Safe Working Loads [kN]		
	Joist				$R_{1,k}$			$R_{1,SWL}$		
	Hanger		FMS Strap		2.8 N/mm ² ; Solid AAC	3.5 N/mm ² Solid LAC	7 N/mm ² Solid DAC	2.8N/mm ² Solid AAC	3.5N/mm ² Solid LAC	7N/mm ² Solid DAC
	Qty	Type	Qty	Type						
SFLH	2	N3.75 x 30	3	N3.75 x 30	6.8	7.9	7.9	3.9	4.5	4.5

SFLH
Safety Fast Lite Hanger - Solid Joists

Installation

Installation

Step 1: Build masonry to the required level, ensuring any coursing bricks or blocks are at least one course below the supporting block.

Leave the masonry to cure for at least three days.

Step 2: Place the Safety Fast Lite Masonry Hanger (SFLH) over the inner leaf of the block work, ensuring the top flanges are fully bearing onto the top of the supporting block work and are also tight against the front face of the block work.

Step 3: Install the floor joist into the SFLH. The end of the joist should be tight against the back of the hanger. Maximum gap allowed: 6mm.

Install the specified joist nails (see table below).

Step 4: Install the appropriate restraint strap (see installation notes), ensuring the strap is tight against the back face of the block work hanger return and the side of the floor joist.

Fix with 3 x 3.75x30mm square twist nails.

Working on the floor prior to the next lift of masonry:

1. The floor decking may be stored on the joists provided the load is uniformly distributed among several joists and does not exceed the hanger or joist capacities. Refer to joist manufacturer or supplier for joist capacity and maximum construction loads.

2. The floor decking must be securely attached to each joist before additional loads can be placed on the system.

3. Pallets of blocks or other construction material should be placed onto the scaffolding and not directly onto the floor.

The materials can then be evenly distributed around the floor manually, ensuring the hanger or joist capacities are not exceeded.

For example, total number of blocks per pair of joists (4 hangers) @ 600 c/c:

- 2.8N/mm² AAC = 24
- 3.5N/mm² AAC = 20
- 7.0N/mm² DAC = 16

Note: I-joist shown for illustration purposes, SFLH is compatible with solid sawn joists.

